



Abstract: With the strong mandate to sustain high annual data availability throughout the network in face of harsh environmental, logistical, and meteorological challenges, it becomes imperative to design power systems with increased resiliency, added redundancy and trusted components, which passed the test of time. The design and deployment of the next-generation IMS power systems thus creates a window of opportunity to modernize station design, minimize catastrophic failures at the selection stations, and incorporate the latest technological advancements at new installations or station upgrades as part of the forthcoming IMS network recapitalization period. The next-generation IMS power systems are based on the open system architecture concept, utilizing ad-hoc selection and substitution of various power sources and power system components derived from the environmental demands and logistical restrictions present at the station location. These purpose-built, yet standardized power systems thus adapt to the site-specific input and output requirements, without requiring extensive redesign and cost when deployed at other stations throughout the IMS network. The high degree of standardization simplifies installation, maintenance and future upgrades as components can be freely interchanged throughout their life cycle without impacting the overall system.

OBJECTIVE:

Design flexible power system platform which supports integration of multiple technologies and facilitates flexible exchange of system components according to site-specific environmental conditions.

DESIGN REQUIREMENTS:

- Reliable**, purpose-built power systems to suit all IMS environments without the need of station-by-station redesign
- Modular approach**, which is flexible but also provides uniformity across all use cases, in support of both efficient operations and economies of scale
- Open system architecture**, supporting ad-hoc substitutions of power system components, easily adaptable to site-specific and power input and output needs and environmental conditions
- Fully autonomous, independent power sources**, integrated with "smart" networked devices facilitating real-time State of Health (SOH) monitoring, remote component management, and alert notifications
- "Clean Power"**: Power system components must not compromise data quality within the Seismic, Hydroacoustic, and Infrasound (SHI) IMS frequency band of 0.02-100 Hz
- "Design for Deployment"** to facilitate simplified field installation and reduced technician competency (i.e. modular subassemblies, pre-connectorized cable harnesses with keyed connectors, etc.)

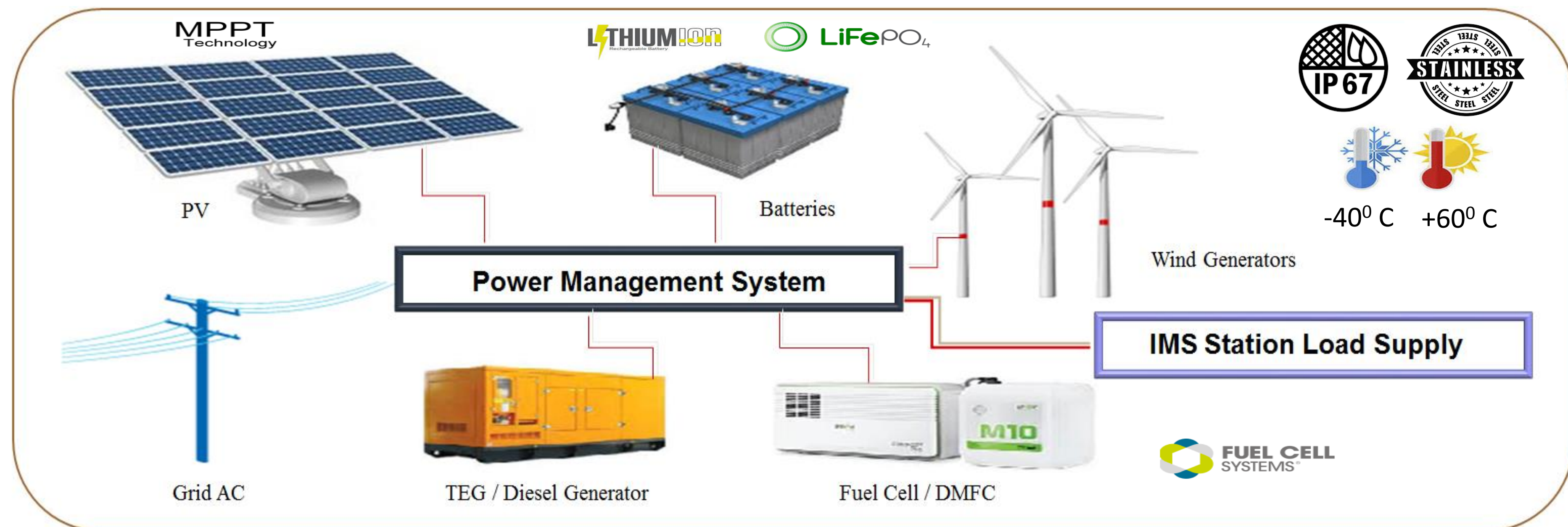

APPROACH:

POWER SYSTEMS CATEGORIZED BY IMS STATION LOAD & ENVIRONMENTAL REQUIREMENTS:

REMOTE STATION POWER SYSTEM PLATFORM		
Category I	Load ≤ 40 W	Most IMS SHI stations without Global Communications Infrastructure (GCI) V-Sat equipment
Category II	Load ≤ 200 W	Auxiliary Seismic stations with GCI equipment
CENTRAL RECORDING FACILITY (CRF) POWER SYSTEM PLATFORM		
Category III	Load ≤ 3 kW	Central Recording Facilities (CRFs)
Category IV	Load 5–10+ kW	CRFs also supplying power to the remote elements (IMS RN Stations with higher load requirements)
Category V	Polar Regions	Category I-IV power systems with hardened components for extreme power environments

REMOTE STATION PLATFORM ARCHITECTURE V1.0 (20180629-1)

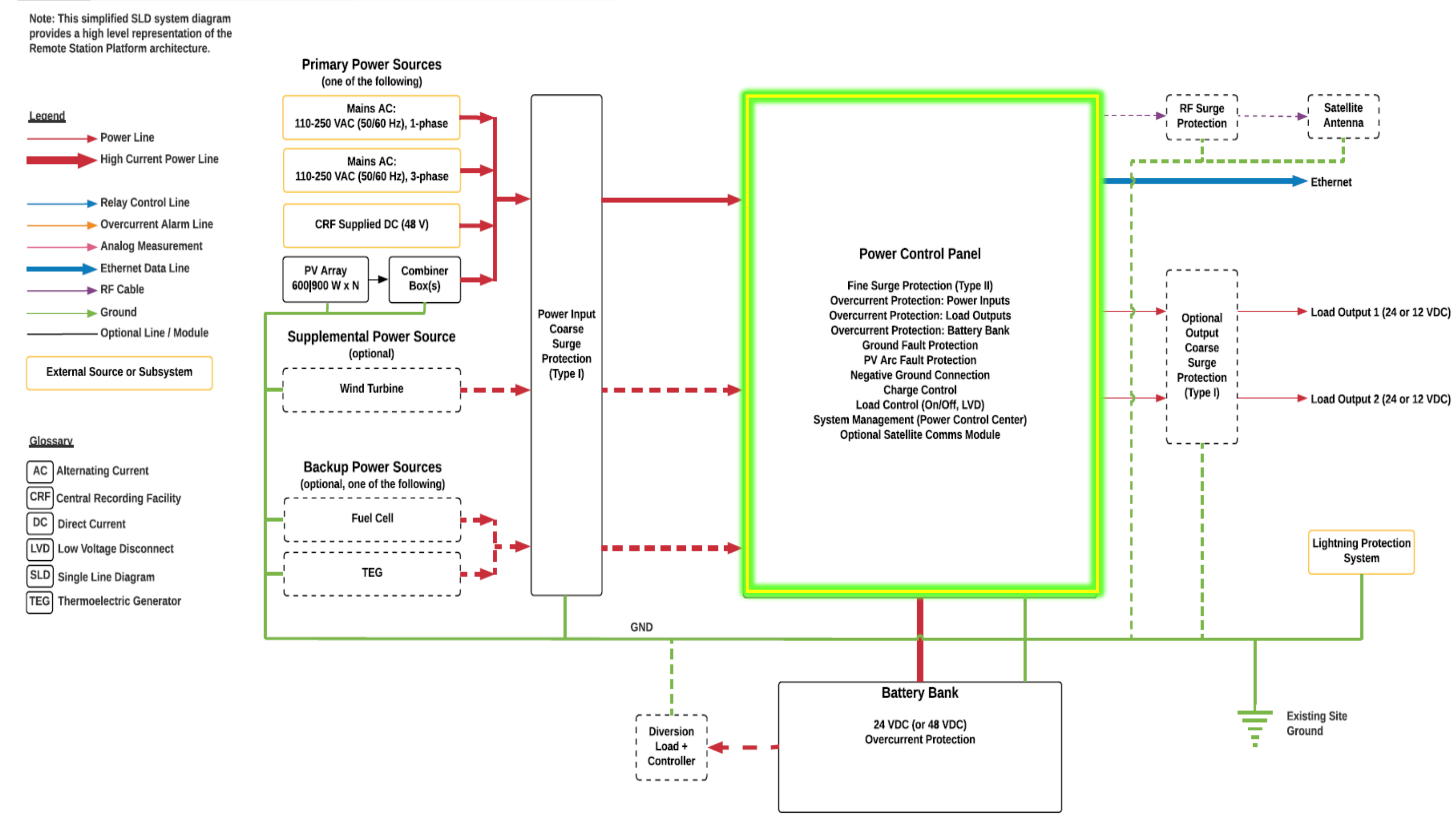

DESIGN:

- Power system management administered by the self-contained, fully integrated **POWER CONTROL PANEL (PCP)**, housed inside single, highly-customizable enclosure (< IP67), with all components DIN-rail mounted
- Pre-allocated space reserved for all system components to achieve standardization (i.e. different charge control models of various sizes fit without affecting the layout or placing of other subsystem components)
- Flexible **open-system** platform facilitates free inter-change of charge controllers depending on the site-specific use case and power source
- Battery bank capacity is scaled up or down to achieve the desired backup power autonomy (all battery chemistries supported, incl. Lithium)

Power Control Panel (PCP):

RSP POWER CONTROL PANEL SYSTEM DIAGRAM V1.0 (20180629-1)

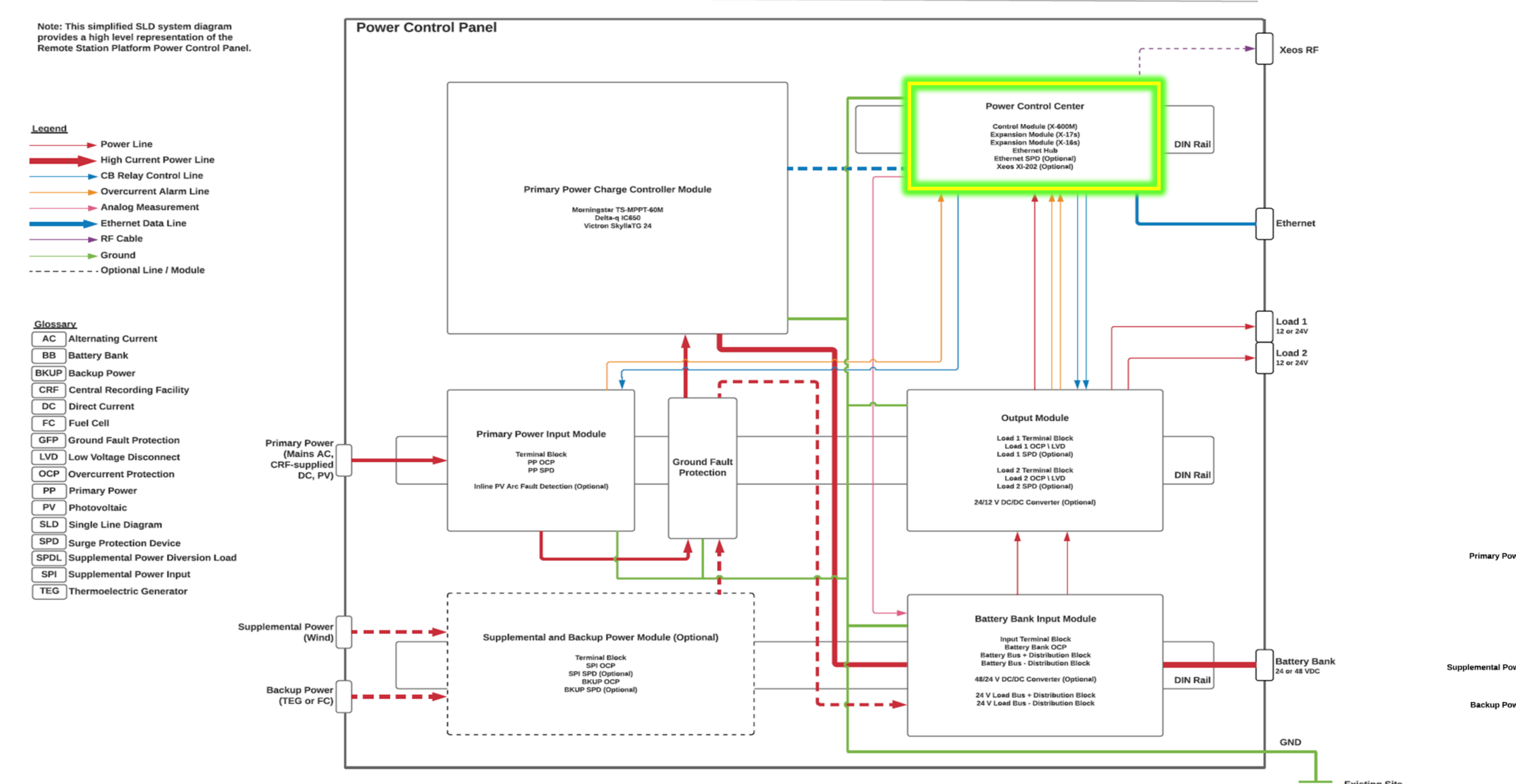

Power Control Center (PCC):

- Provides **remote control**, SOH monitoring, and event notification of critical subsystems (key in mission-critical networks)
- Contains **ControlByWeb X-600M** I/O controller with **X-16s** & **X-17s** expansion modules for IP-enabled monitoring & control
- Asynchronous alerts may be generated via SNMP traps for fault conditions and alarms. Depending on component selection, system control functions may include: Input power overcurrent alarm & remote reset, PV primary power disconnect on arc fault detection, multiple Low Voltage Disconnects (LVDs), Load on/off control, etc.
- B+B SmartWorx ESW205-T** Ethernet Hub supports interface with IP-enabled charge controllers
- For added redundancy, **Xeos XI-202** Iridium-based Short Burst Data (SBD) satellite communications terminal may be included to maintain remote monitoring and control in the event of primary communication link interruptions or outages.

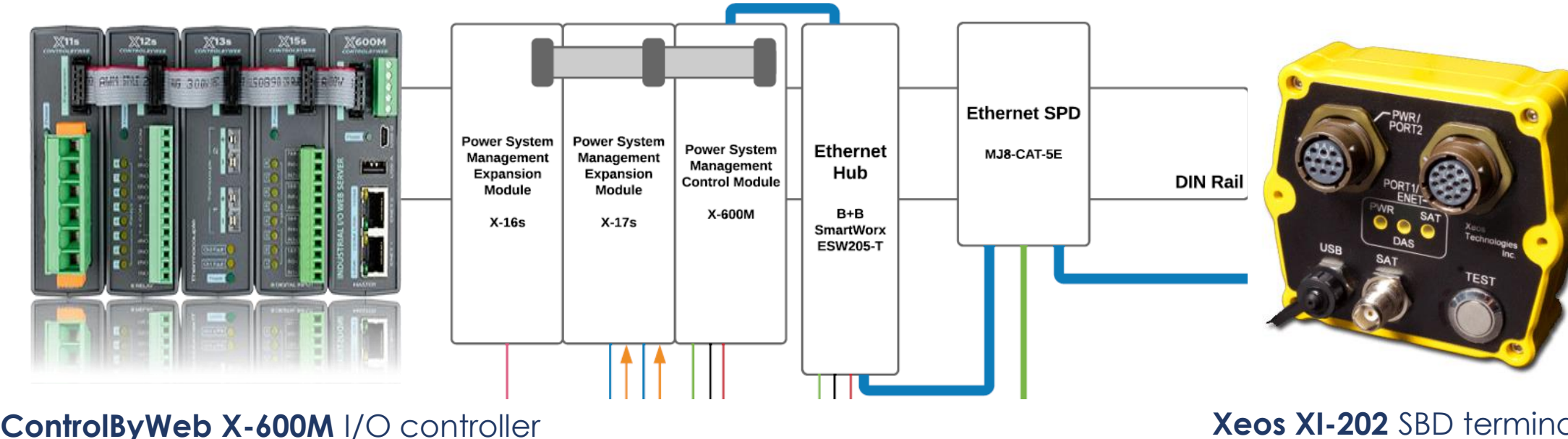

Disclaimer: The views expressed on this poster are those of the author and do not necessarily reflect the view of the CTBTO