

# OOI Regional Cabled Array Winched Profiler Data for Improved Hydroacoustic Analyses

19-06-27\_1430\_Cram\_T1.3-08

CTBT Science and Technology 2019 Conference  
24-28 June 2019

**Geoff Cram, Mike Harrington, Kellen Rosburg, Kevin Williams, Lisa Zurk**

Applied Physics Lab, University of Washington

1013 NE 40<sup>th</sup> St

Seattle, WA 98115



Applied Physics Laboratory  
UNIVERSITY of WASHINGTON

**W**  
UNIVERSITY of  
WASHINGTON

# Introduction

- The Applied Physics Laboratory at the University of Washington (APL-UW)
- The Ocean Observatories Initiative Regional Cabled Array (OOI-RCA)
- Example profiler data from the OOI-RCA
- Relevance to future modular IMS HA stations

# APL-UW

- Founded in 1943 at the University of Washington
- Vertically integrated
  - We design, build, deploy and conduct science with our systems

## Core Competencies

- Underwater Instrumentation and Equipment Development
- Ocean Acoustic Propagation and Systems
- Experimental Oceanography
- Mission-Related and Public Service Rapid Response R&D and Engineering
- Simulation and Signal Processing

# Regional Cabled Array

- Multipurpose cabled ocean observatory, funded by the US National Science Foundation Ocean Observatories Initiative
- Implemented by the APL-UW in conjunction with the UW School of Oceanography
- Installation completed in 2014
- 25 year system design life, going strong
- Star topology with expansion capacity for ew instruments/projects

# RCA Overview

## RCA ELEMENTS

### Design Facts

- 2 cables (~900 km)
- 1 Landing
- 1 Cable Station
- 2 Scientific sites
- 7 Primary Nodes

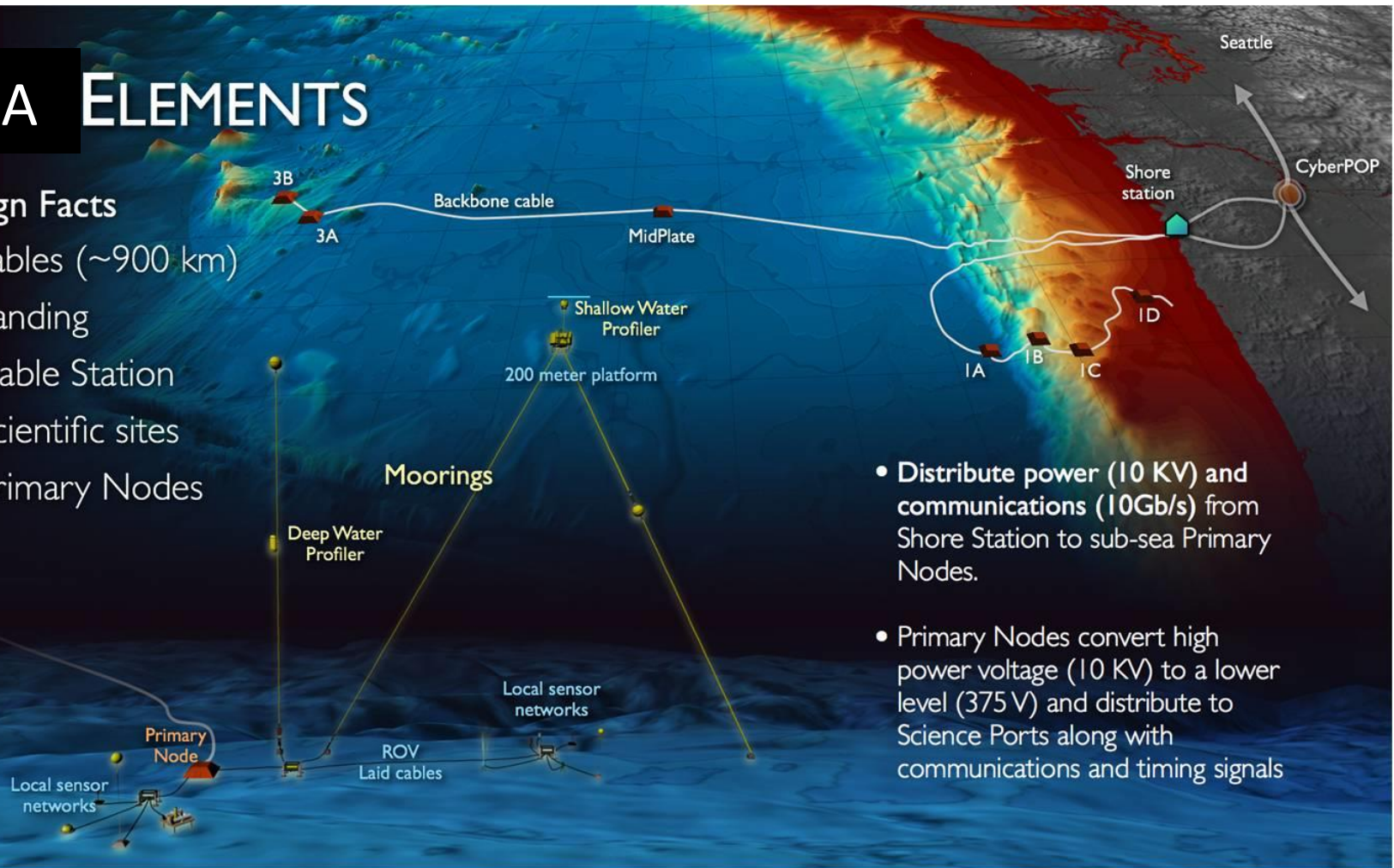

- Distribute power (10 KV) and communications (10Gb/s) from Shore Station to sub-sea Primary Nodes.
- Primary Nodes convert high power voltage (10 KV) to a lower level (375 V) and distribute to Science Ports along with communications and timing signals

# RCA Infrastructure in 2019

- 890 km of backbone cable
- 7 primary nodes
  - 5 available ports
- 18 seafloor junction boxes
  - 10 available ports
- 6 profiling moorings
- 150 oceanographic instruments, majority reporting in real time

# RCA Junction Boxes

- Junction boxes developed by APL to power and communicate with instruments
  - 18 junction boxes currently installed on the RCA
    - Grade 5 titanium pressure housings for custom power and communications electronics, mounted in steel frames with ROV wet-mate connector panels

	Number of Instrument Ports	Output Port Voltage	Maximum Power per Output Port	Maximum Total Power	Protocols
Medium Power Junction Box	8	12 VDC	200 W	1.6 kW	10/100BASE-T
Low Power Junction Box	8	24 VDC	50 W	150 W	EIA-232
		48 VDC			EIA-422
					EIA-485

# RCA Junction Box Deployment



# Installed RCA Junction Box

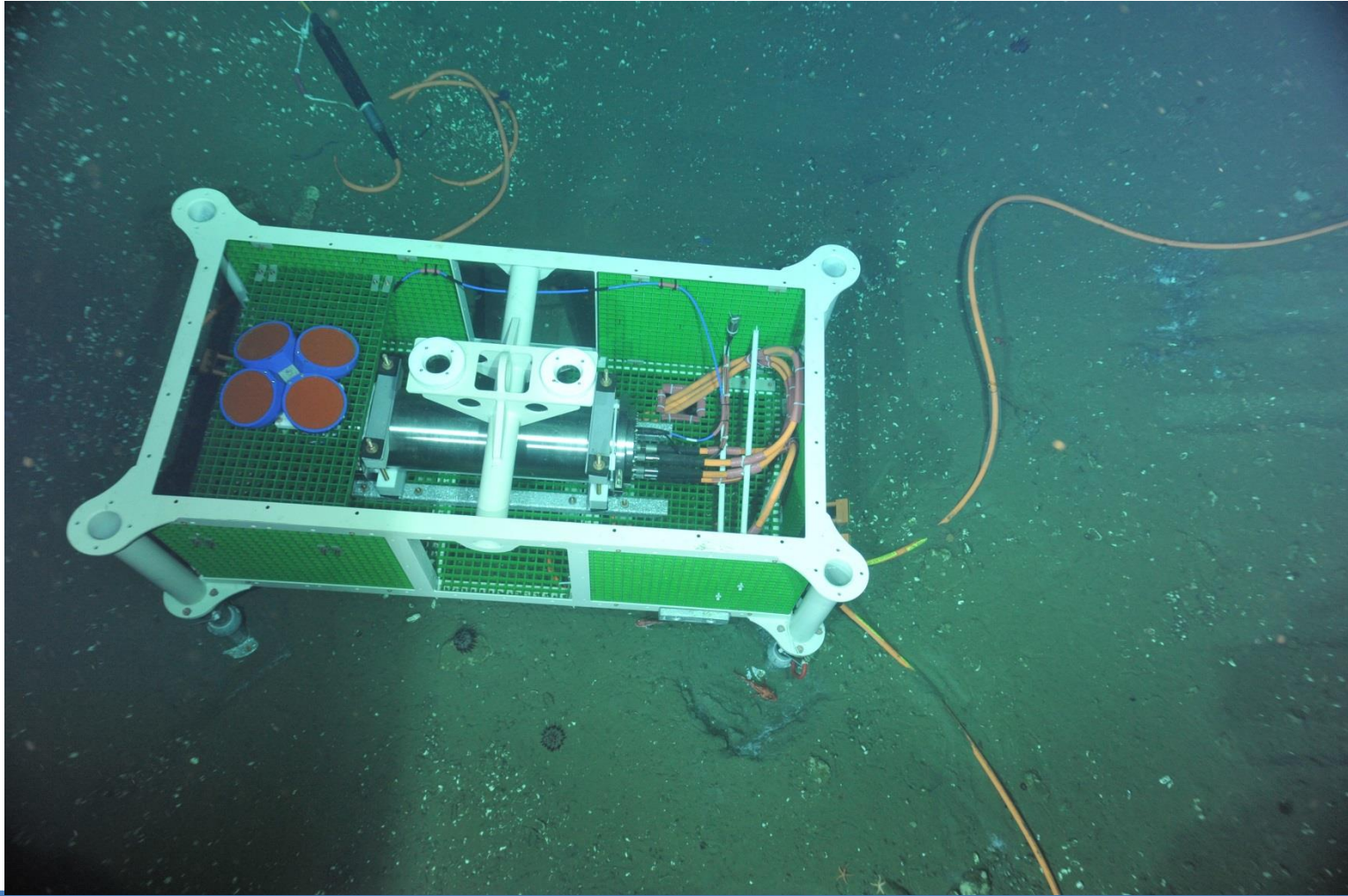

# RCA Junction Box Connector Panel

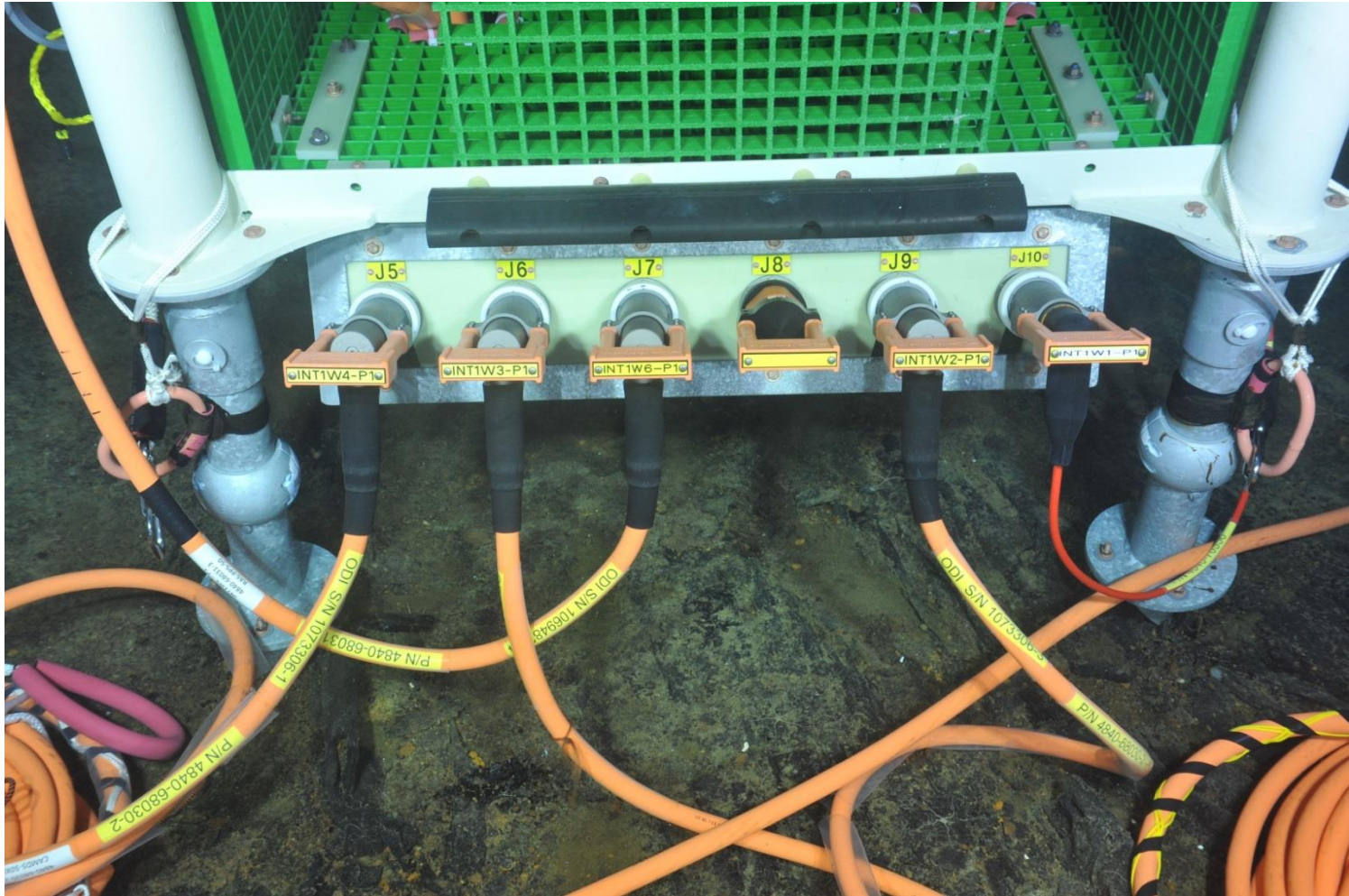

# RCA Cable Deployment by ROV

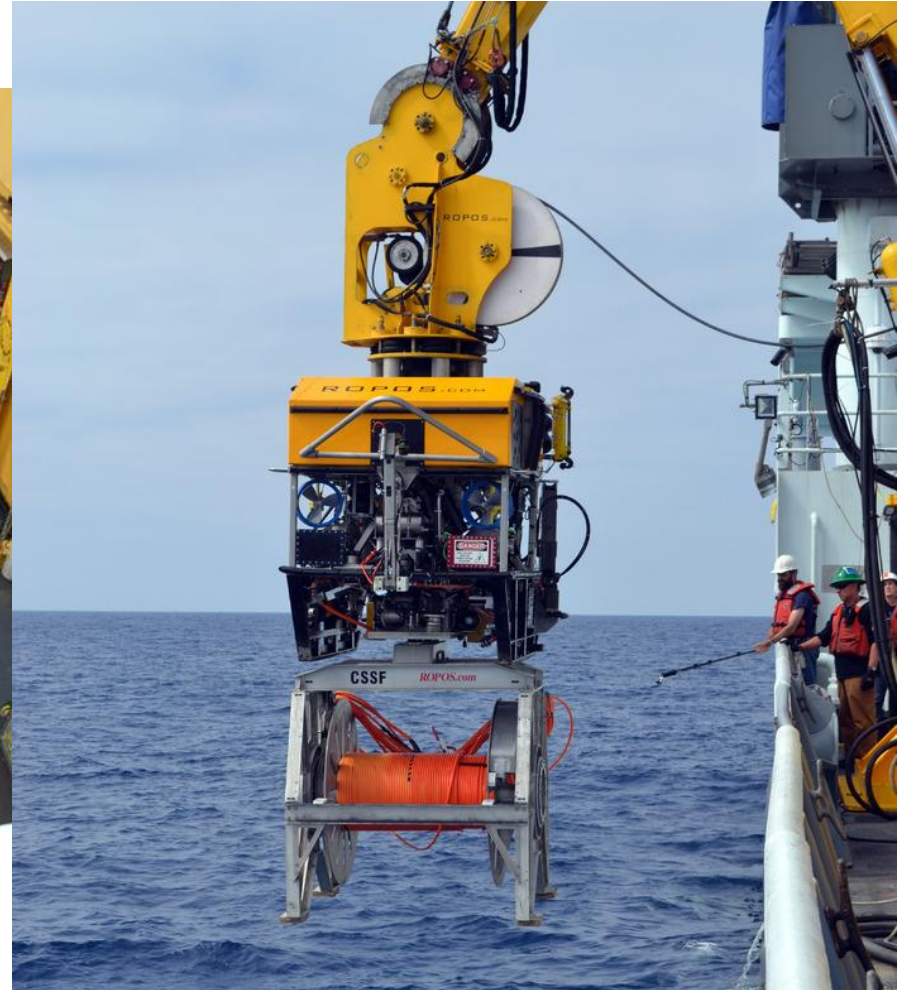

# RCA Instruments

- 150 instruments installed on RCA
- 35 types (8+ custom, 27 commercial)
- Instrument examples:
  - Hydrophones
  - Seismometers
  - Pressure sensors
  - Water chemistry
  - HD camera
  - CTD
  - Optical

HD Camera trained on black smoker vent

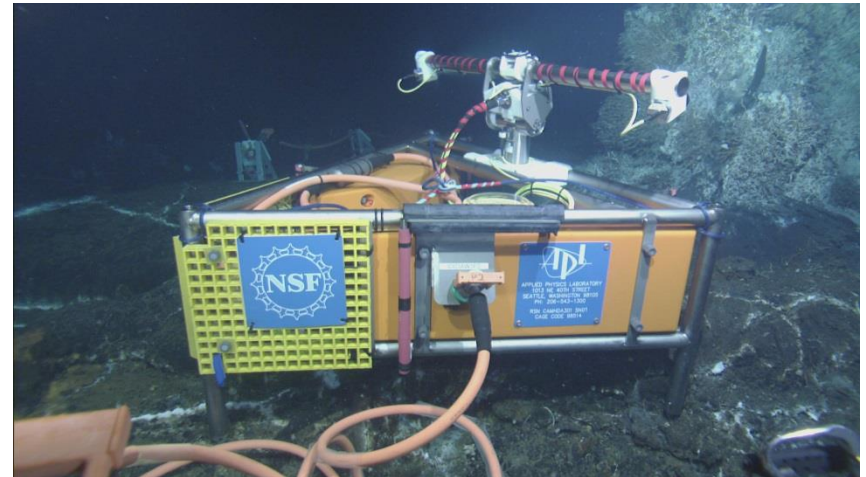

# RCA 2-Leg Moorings with Profilers

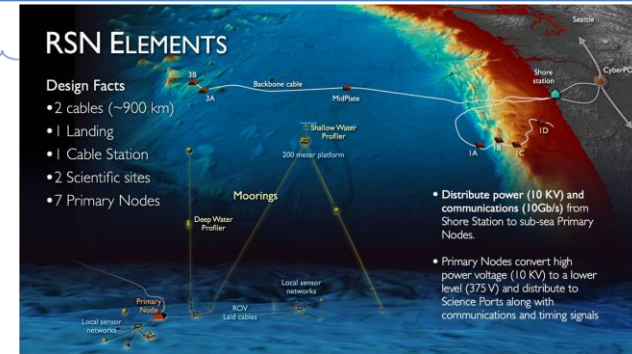
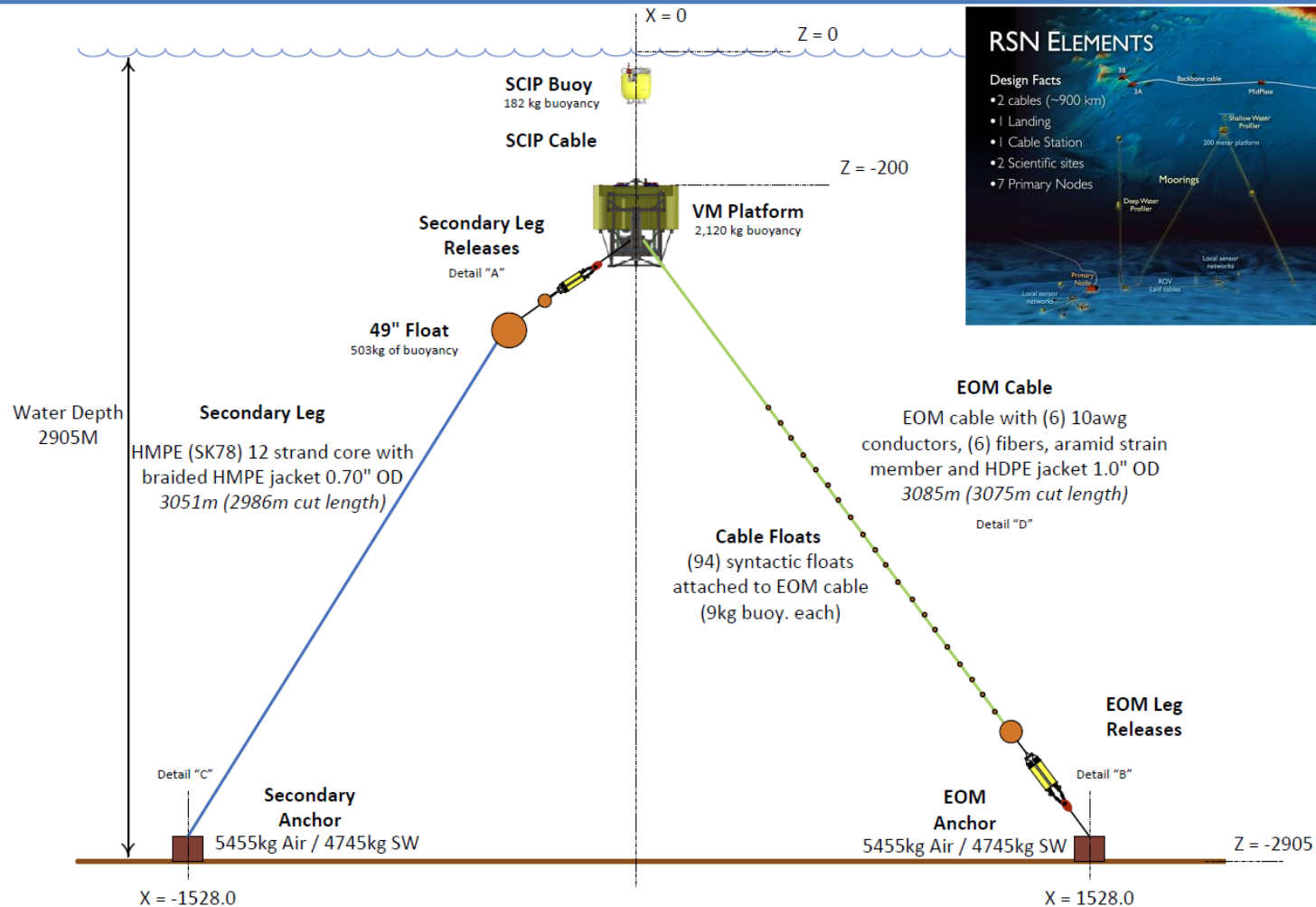

# RCA Installation



Shallow Profiler

# 2014-2019 Seasonal Profiles at Slope Base

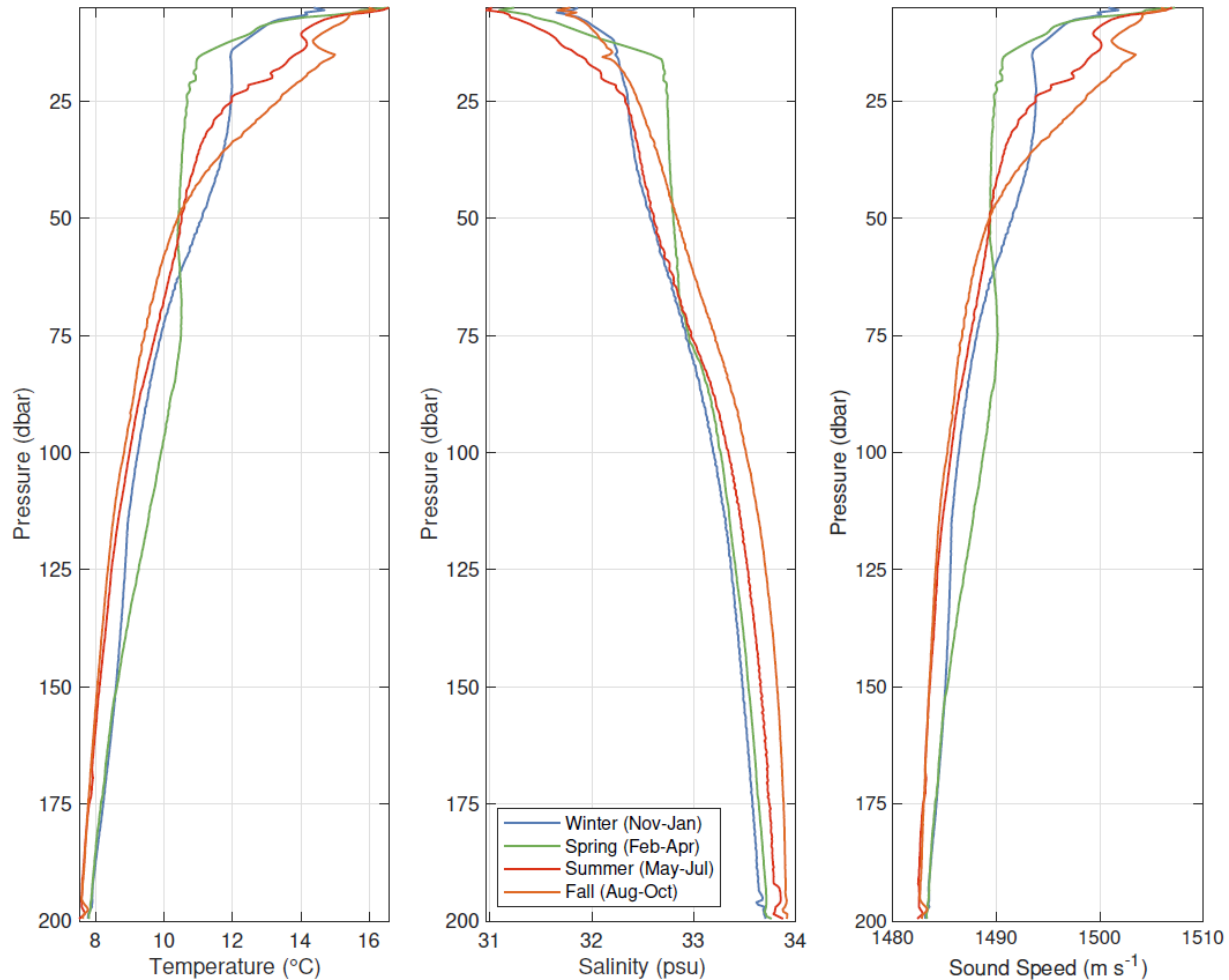

# 2015-2017 Depth-Temperature Sections at Axial Base

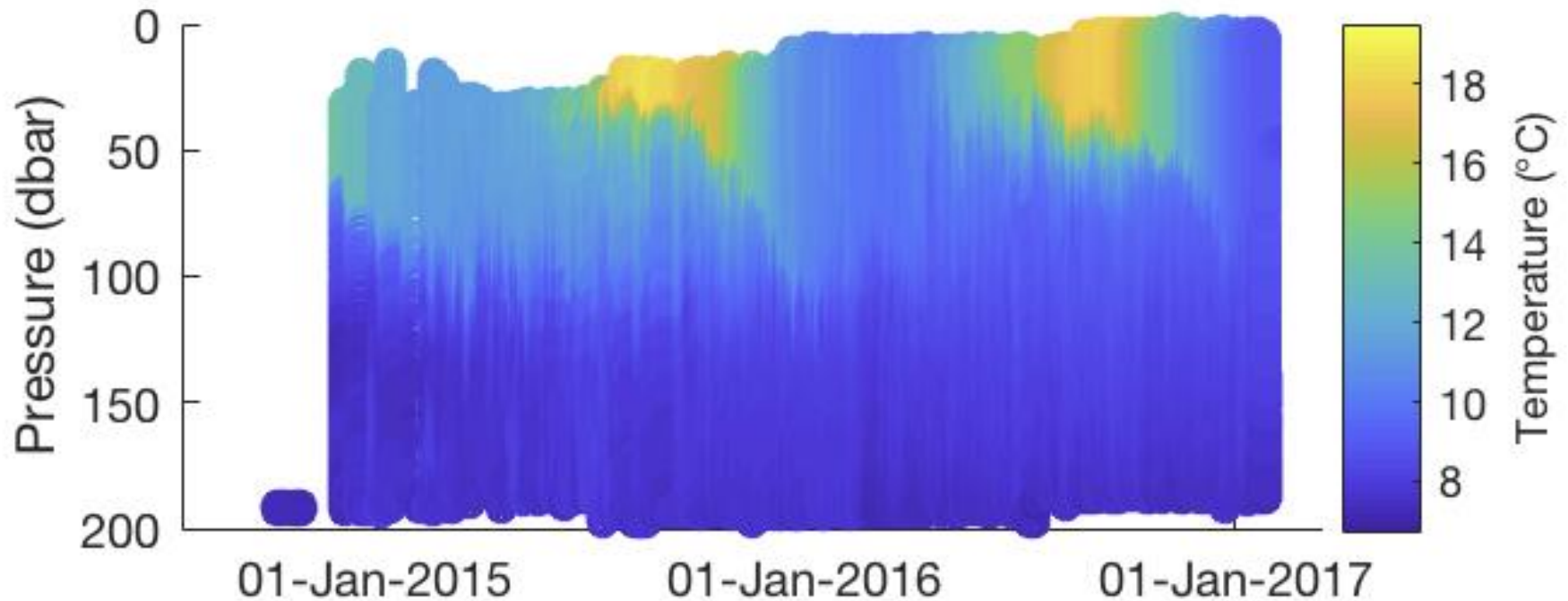

# 2016 Wind & Temperature vs Depth at Endurance Offshore

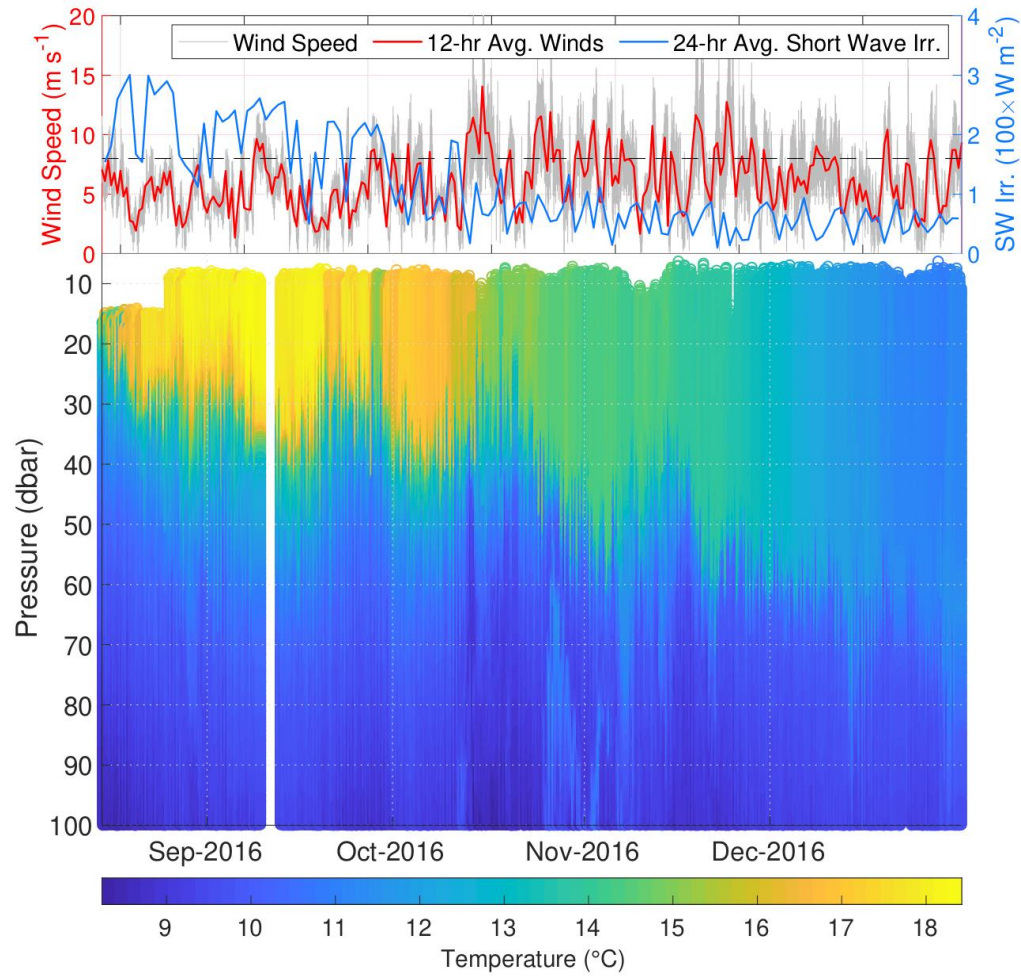

# 2014-2019 Temperature & Wind Spectra at Slope Base

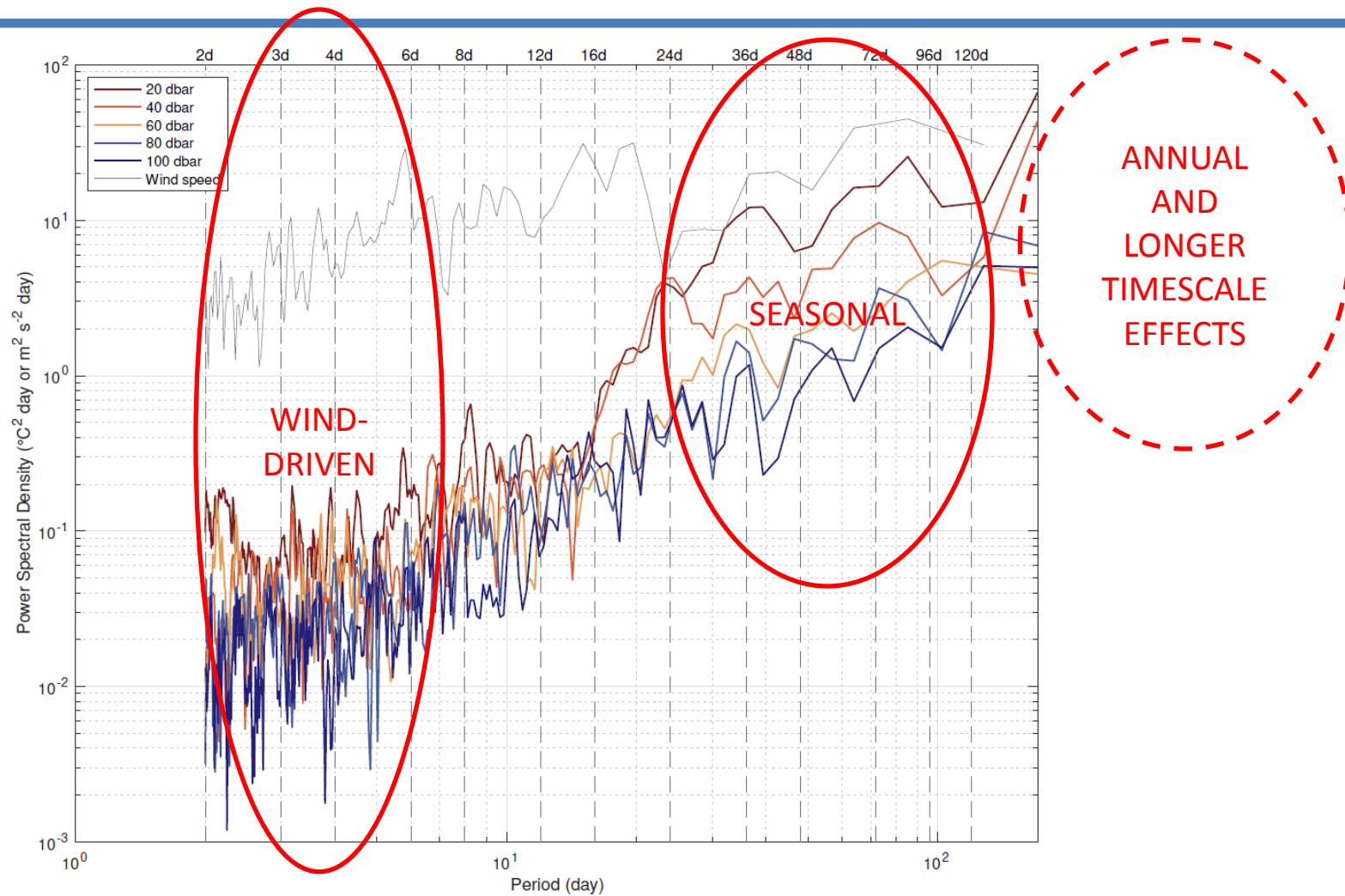

# Relevance to the CTBTO

- APL-UW is working with the PTS to develop a modular design for next generation hydroacoustic systems in order to enhance sustainability.
- As part of a modular HA system, it would be straightforward to include an extra port to permit attachment of an oceanographic instrument (e.g. CTD or other device)

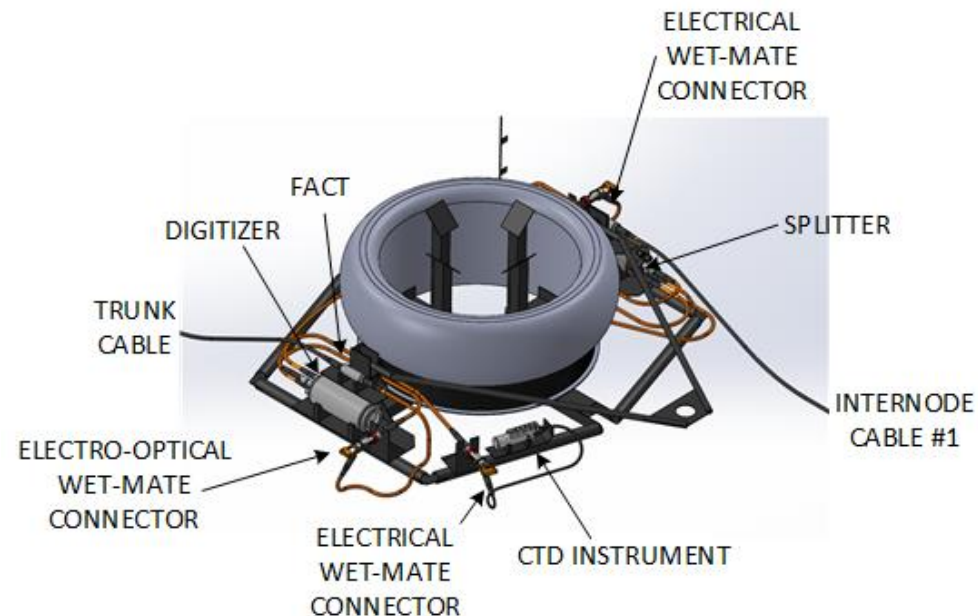

# In Support of Long Duration Measurements

**Any useful ocean observation system must be open-ended in time---there is no low-frequency cut-off to the time scales over which the system is capable of change, and new physics always enters as the time scale increases.**

**Design considerations must thus include the ability to sustain a high quality system indefinitely so that those long times are ultimately observed.**

*-Carl Wunsch*

*OBSERVATIONAL NETWORK DESIGN FOR CLIMATE, 2009*